



2 Test Indicator

Dial Test Indicators are designed to be positioned for easy and accurate readability and are applicable for various usages such as measuring dimension, parallelism and centering of work piece and measuring revolution axis of machinery equipment and turnout of work pieces processed by lathe etc., and making table face of machinery equipment parallel. This has strong point if compared with standard dial indicator and has sensitivity for microscopic dimension displacement measurement. As its stylus is leg type with ball edge, narrow space can be measured, where its edge (standard $\phi 2\text{mm}$ ultra hand ball) can enter. $\phi 0.6\text{mm}$, $\phi 0.8\text{mm}$ and $\phi 1.0\text{mm}$ are available.



Leveling, parallelism and center run out of work piece are measured by fixing lever test with holder or chuck and moving work piece. Above photo shows that leveling is measured by installing test indicator to electric discharge machine machining center.

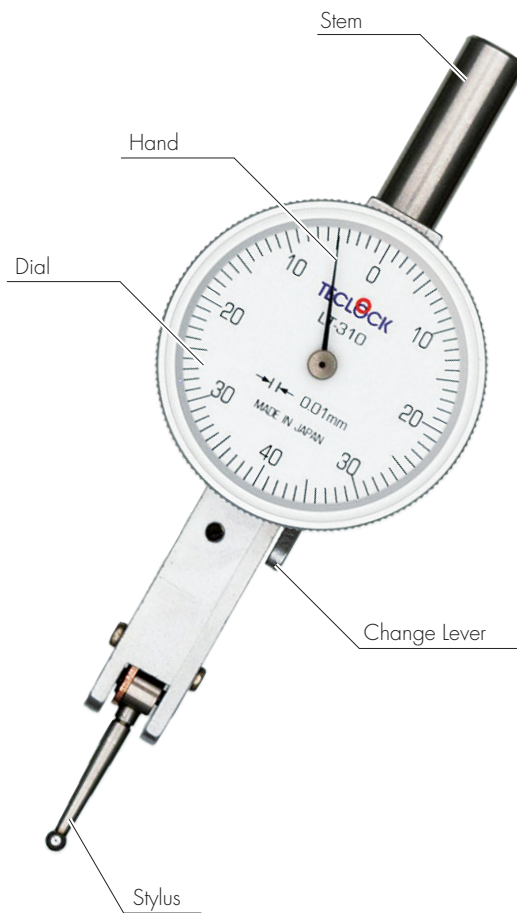



Lever type Test Indicators

- Measuring direction can be changed with change lever.
- Main bearings are jeweled for all models.
- A carbide ball stylus is provided for less abrasion.
- Stylus is made of $\phi 2\text{mm}$ stainless steel and it is unique threaded type which can be changed easily.
- Stylus and pointer are anti-magnetic and not affected by magnetism.
- Due to the low measuring force, this is suitable for measurement of thin work piece as well.

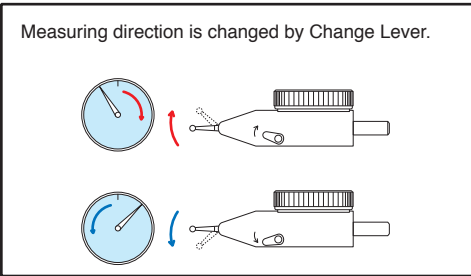

PS type Test Indicator

- Shock from the angle excepting measuring direction can be avoided and body is protected by Teclock original shock preventing mechanism (PS mechanism) of center of stylus.

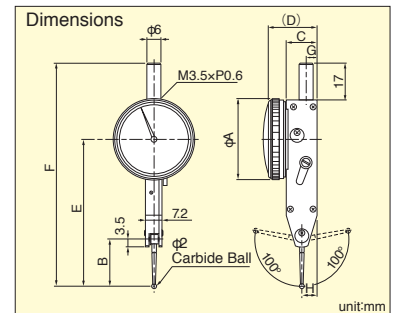
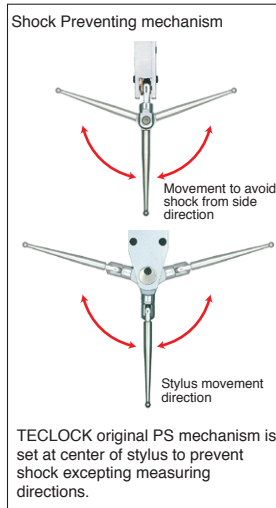
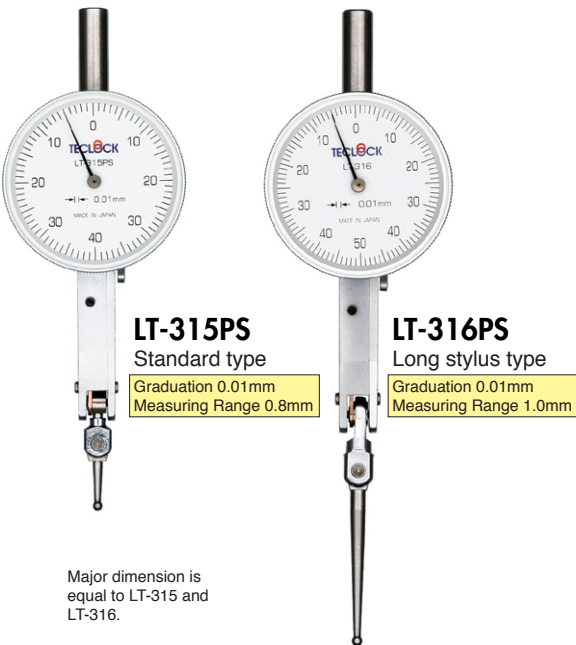

Dimensions Table

Model	A	B	C	D	E	F	G	H
LT-310	28.4	15.3	14	22.4	47.3	79.3	5	7
LT-311	35	15.3	14	23.3	47.3	79.3	5	7
LT-314	35	21.5	13.5	23	64.5	98.5	4.8	6.8
LT-315	35	20.1	13.5	23	63.1	97.1	4.8	6.8
LT-316	35	42.9	13.5	23	85.9	120	4.8	6.8
LT-370	38.4	12	13.5	23.2	55	89	4.8	6.8

unit:mm

Specifications

Model	Graduation (mm)	Measuring Range (mm)	Dial Reading	Measuring Force	Repeatability (μm)	Adjacent Error (μm)	Accuracy on full range (μm)	Hysteresis (μm)	Standard Stylus	Weight (g)
LT-310	0.01	0.8	0-40-0	0.4 or less	3	5	8	3	ZS-700	50
LT-311	0.01	0.8	0-40-0	0.4 or less	3	5	8	3	ZS-700	60
LT-314	0.01	0.5	0-25-0	0.4 or less	3	5	5	3	ZS-701	70
LT-315	0.01	0.8	0-40-0	0.4 or less	3	5	8	3	ZS-702	70
LT-316	0.01	1.0	0-50-0	0.4 or less	3	5	10	4	ZS-704	70
LT-370	0.002	0.28	0-140-0	0.4 or less	1	2	3	2	ZS-713	75
LT-315PS	0.01	0.8	0-40-0	0.4 or less	3	5	8	3	ZS-703	70
LT-316PS	0.01	1.0	0-50-0	0.4 or less	3	5	10	4	ZS-705	70



Auto-Clutch Test Indicators

- As miniature bearing (pivot ball bearing) is used for stylus revolution bearing. It is not affected by shaft looseness and indication is stable.
- Measuring direction is automatically changed for proper and opposite by auto-clutch mechanism without changing lever. It is always read accurately in any case, as stylus rotates in clockwise direction..
- Stylus can be set at any desired position of angle of 220 °circle.
- Stem with dovetail groove (Option) can be mounted to 2 points of front and back part.
- A carbide ball stylus is provided for less abrasion and stylus is made of stainless steel..
- Stylus and pointer are anti-magnetic and not affected by magnetism.

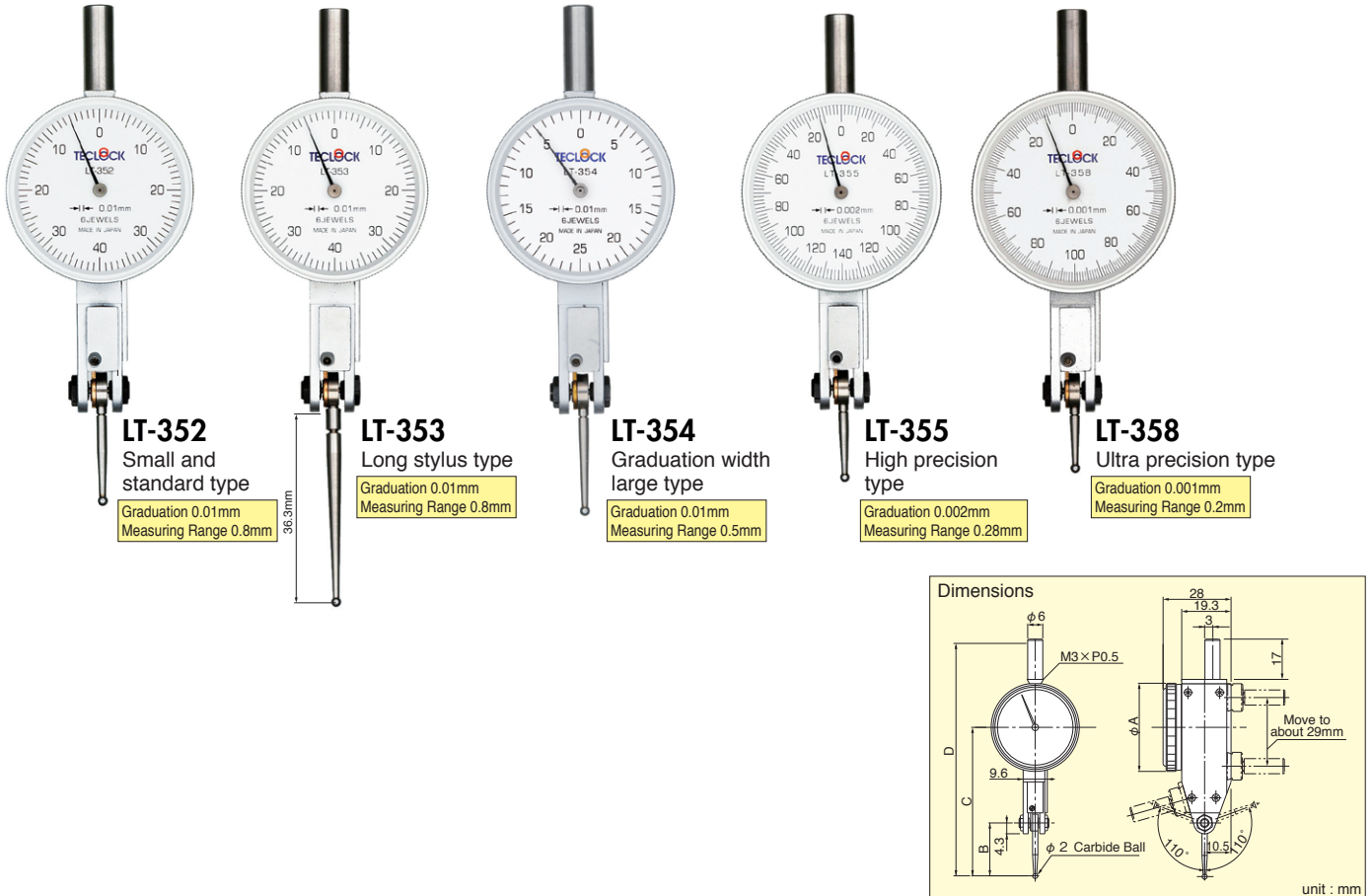

Specifications

Model	Graduation (mm)	Measuring Range (mm)	Dial Reading	Measuring Force	Repeatability (μm)	Adjacent Error (μm)	Accuracy on full range (μm)	Hysteresis (μm)	Standard Stylus	Weight (g)
LT-352	0.01	0.8	0-40-0	0.2 or less	3	5	8	3	ZS-709	75
LT-353	0.01	0.8	0-40-0	0.2 or less	3	5	8	4	ZS-710	75
LT-354	0.01	0.5	0-25-0	0.2 or less	3	5	5	3	ZS-799	75
LT-355	0.002	0.28	0-140-0	0.25 or less	1	2	3	2	ZS-711	75
LT-358	0.001	0.2	0-100-0	0.25 or less	1	2	3	2	ZS-712	75

Dimensions Table

Model	A	B	C	D
LT-352	35	21	59	95
LT-353	35	40.6	78.6	114.6
LT-354	35	25.4	63.4	99.4
LT-355	38.4	18	56	92
LT-358	38.4	15	53	89

unit : mm

Stems with dovetail slot for Auto-Clutch Test indicator (Option)

Standard stem diameter is 6mm but φ4mm and φ8mm are also available on request

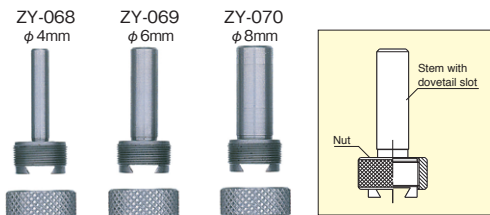

Applicable for LT-352, LT-353, LT-354, LT-355, LT-358



Auto-Clutch Test Indicators (Low measuring force)

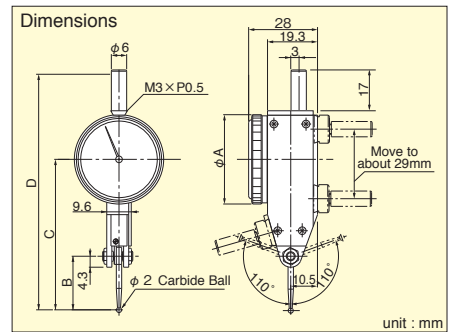
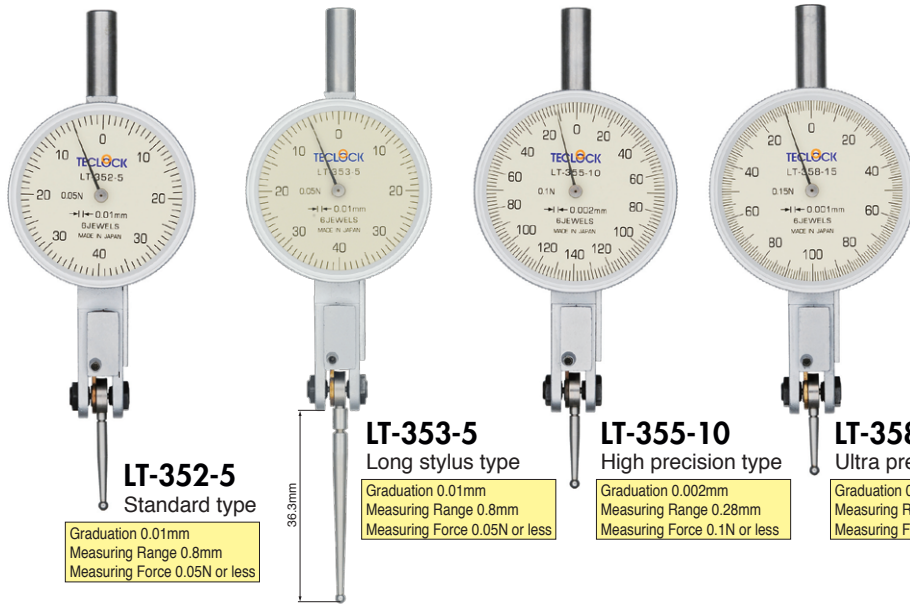

Dimensions Table

Model	A	B	C	D
LT-352-5	35	21	59	95
LT-353-5	35	40.6	78.6	114.6
LT-355-10	38.4	18	56	92
LT-358-15	38.4	15	53	89

unit : mm

Specifications

Model	Graduation (mm)	Measuring Range (mm)	Dial Reading	Measuring Force	Repeatability (μm)	Adjacent Error (μm)	Accuracy on full range (μm)	Hysteresis (μm)	Standard Stylus	Weight (g)
LT-352-5	0.01	0.8	0-40-0	0.05 or less	3	5	8	3	ZS-709	75
LT-353-5	0.01	0.8	0-40-0	0.05 or less	3	5	8	4	ZS-710	75
LT-355-10	0.002	0.28	0-140-0	0.1 or less	1	2	3	2	ZS-711	75
LT-358-15	0.001	0.2	0-100-0	0.15 or less	1	2	3	2	ZS-712	75

Lever Test Indicator for Deflection

- This is the special indicator to check deflection level not deflection volume.
- Deflection which can not be measured with standard type can be checked by installing stylus depending on the shape of work piece.
- Unit is not available for gradation line. (Calibration certificate can not be issued.)
- Standard price of LR-316 does not include stylus. Select the stylus from the list below and use indicator by combining it.

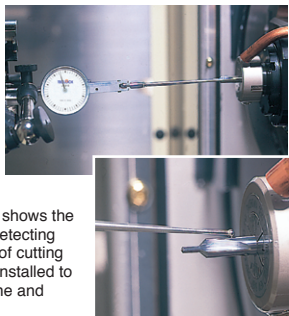

The photo shows the scene of detecting deflection of cutting tool edge installed to the machine and deflection.

LR-316
for Run-out (TIR) measurement

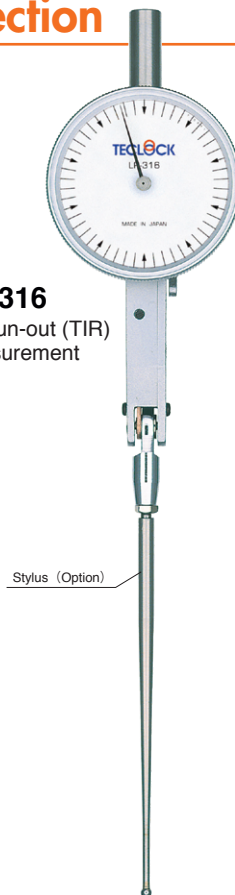

Stylus (Option)

Specifications

Model	Weight (g)
LR-316	70

LR-316 stylus (with Fixing Nut)

Code No.	Shape of stylus	L (mm)	Dimensions (mm)
ZS-777	Spherical Shape	25.8	
ZS-782		68.7	
ZS-778	Half Spherical Shape	25.8	
ZS-783		68.7	
ZS-779	Fan Shape	25.8	
ZS-784		68.7	
ZS-780	Square Shape	25.8	
ZS-785		68.7	
ZS-781	Round Bar Shape	25.8	
ZS-786		68.7	



Parts & Accessories

Stylus

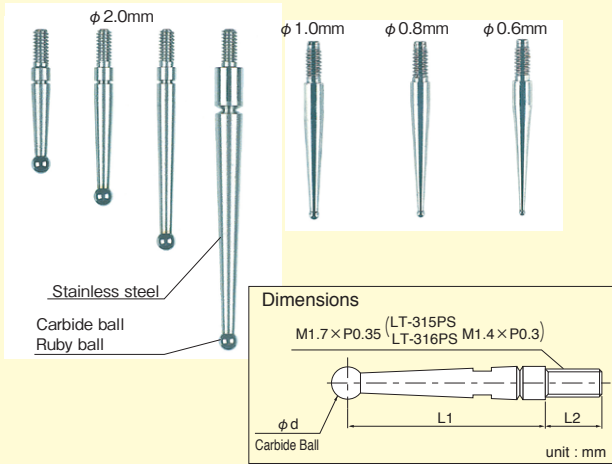
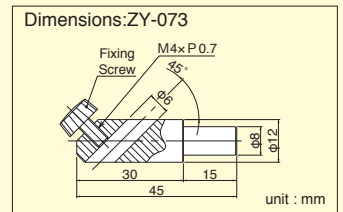
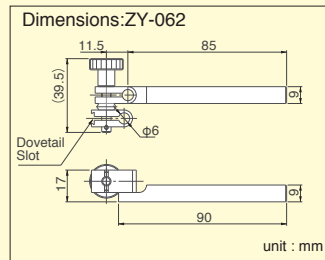
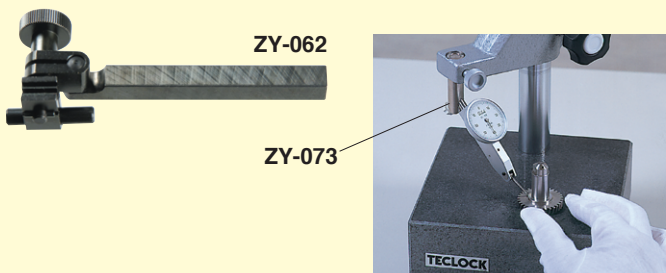

Table for applicable Stylus and Parts

Model	L1 (mm)	L2 (mm)	φd (mm)				
			φ0.6	φ0.8	φ1.0	φ2.0(Standard)	φ2.0(ルビー球)
LT-310	13.30	4.00	ZS-744	ZS-755	ZS-766	ZS-700	ZS-787
LT-311	13.30	4.00	ZS-744	ZS-755	ZS-766	ZS-700	ZS-787
LT-314	19.45	4.00	ZS-745	ZS-756	ZS-767	ZS-701	ZS-788
LT-315	18.10	4.00	ZS-746	ZS-757	ZS-768	ZS-702	ZS-789
LT-316	28.40	4.00	ZS-748	ZS-759	ZS-770	ZS-704	ZS-790
LT-370	10.00	4.00	ZS-754	ZS-765	ZS-776	ZS-713	ZS-795
LT-352	17.80	4.00	ZS-750	ZS-761	ZS-772	ZS-709	ZS-791
LT-353	37.38	4.00	ZS-751	ZS-762	ZS-773	ZS-710	ZS-792
LT-354	22.16	4.00	ZS-811	ZS-812	ZS-813	ZS-799	ZS-815
LT-355	14.80	4.00	ZS-752	ZS-763	ZS-774	ZS-711	ZS-793
LT-358	11.80	4.00	ZS-753	ZS-764	ZS-775	ZS-712	ZS-794
LT-315PS	8.65	1.80	ZS-747	ZS-758	ZS-769	ZS-703	ZS-796
LT-316PS	28.40	1.80	ZS-749	ZS-760	ZS-771	ZS-705	ZS-797

Lever Test Holder

This holder fixes lever test with φ6mm hole or dovetail.



Code No.	Specification
ZY-062	Dovetail slot or φ6mm stem
ZY-073	φ6mm stem (Setting angle 45°)

Parts List

Test Indicators

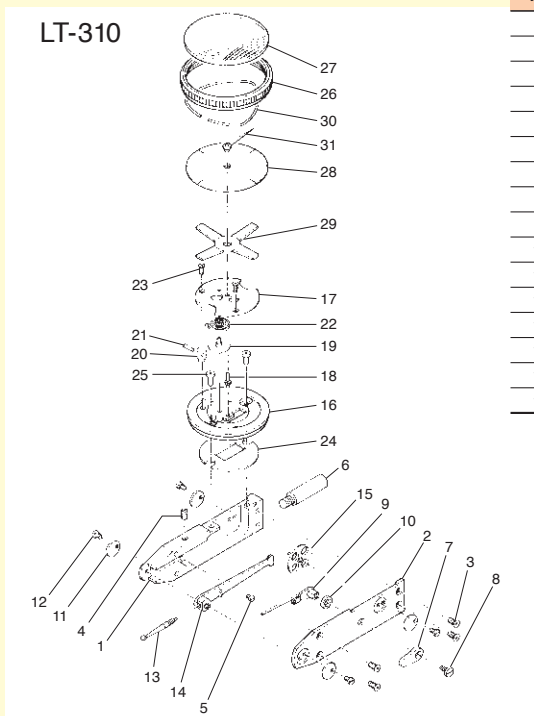

Key No.	Parts No.	Parts name	Key No.	Parts No.	Parts name
1	DG-310001	FRAME	17	DG-310032	UPPER PLATE ASS'Y
2	DG-310002	FRAME COVER	18	DG-310033	CENTER PINION
3	002301	FRAME COVER SCREW	19	DG-310535	2# GEAR ASS'Y
4	DG-310008	STOP SCREW A	20	DG-310037	RECEIVED HAIR SPRING
5	DG-310009	STOP SCREW B	21	DG-310038	HAIR SPRING PIN
6	ZY-030	STEM	22	DG-310539	HAIR SPRING
7	DG-310011	LEVER	23	002301	UPPER PLATE SCREW
8	DG-310012	LEVER SCREW	24	DG-310042	COVER
9	DG-310515	STOPPER ASS'Y	25	001315	BASE PLATE SCREW
10	DG-310016	WASHER	26	DG-310045	BEZEL
11	DG-310017	FULCRUM COVER	27	DG-310046	DIAL COVER
12	001329	FULCRUM COVER SCREW	28	T-5400B	DIAL PLATE
13	ZS-700	CONTACT POINT	29	DG-310048	DIAL PLATE SPRING
14	DG-310522	1# FULCRUM ASS'Y	30	DG-310049	BEZEL SPRING
15	DG-310525	CROWN GEAR ASS'Y	31	DG-310551	POINTER
16	DG-310031	BASE PLATE Ass'Y			

Precautions on use of Dial Indicator / Test Indicator

1. Confirmation of performance

Please confirm whether prescribed performance is maintained with implementation of receiving inspection based on purchasers' specifications. Please refer to contents of standard of Dial Indicator JIS B 7503, JIMAS2001, and Dial Test Indicator JIS B 7533 on the occasion of their treatment.

2. Operating environments / storage

- (1) Temperature : 0°C to 40°C, Relative Humidity : 30% ~ 70% (no condensation)
- (2) Please do not use the indicator with little dust, oil mist and where it will be exposed to direct sunlight.
- (3) Please keep it in good condition that oil mist and dust will not be adhered

3. Usage condition

- (1) Dial Indicator : Please do not suddenly displace spindle and not force perpendicular to the spindle.
- (2) Dial Test Indicator : In case of adding more than enough force to contact point from the excepting contact point direction, its performance will get worse or it will be damaged.

4. Precautions on use

- (1) Check before using
 - ① Confirm whether operation is smooth.
 - ② Confirm whether quiescent point of indicator (pointer / short hand) is stable.
 - ③ Dial Indicator : Confirm whether contact point and lug back (back lid) are not loose.
 - ④ Dial Test Indicator : Please confirm whether contact point and stem are not loose. Torque for fastening screws of contact point is to be in the range 1.5 ~ 2.0 kg·cm. If it is fastened too strong, screw part will be damaged.
- (2) Installation method
 - ① Dial Indicator should be installed with only stem or lug back. (Dial Test Indicator should be with stem or dovetail)
 - ② Holding tool should be sufficiently stiff.
 - ③ Whether installation is right or wrong can be confirmed by that the pointer will return to the set position even after contact point of Dial indicator (Test Lever) is touched to measured substance and inner frame (case) is pushed from up and down by finger.
 - ④ Angle of Dial Test Indicator contact point Please set contact point to be perpendicular to measuring direction. In case of measuring large angle, please correct it. Otherwise, angle error will occur.
- (3) Suppose dial is read from oblique direction of outer dial, error will happen. Please read from front face.
- (4) In case of changing contact point and back lid of dial indicator, please use only the parts designated by Teclock.
- (5) In case of changing contact point of dial test indicator, please use only the parts designated by Teclock. As to contact point, please use the same length. As to dial test indicator, since expansion mechanism is provided, large error will occur, in case of using contact point of different length.
- (6) In case of using it where temperature changes, please frequently confirm the setting point of pointer with master gauge etc.
- (7) In case of dropping it down or making impact with it, please use it after inspection.

5. Maintenance, inspection and repair

- (1) In case of operation is deteriorated due to dirt of sliding part of spindle, please wipe stains from the spindle by using a dry cloth or a cloth dampened with alcohol.
- (2) In case that outer dial can not be read due to dirt of crystal, please wipe stains from the crystal by using a dry cloth or a cloth dampened with neutral detergent. Please do not use organic solvent like benzene, thinner and alcohol etc.
- (3) The performance of the indicator may deteriorate depending on the operating environment and conditions. Please determine the inspection period according to user's operating frequency, environment, and method and periodically inspect the performance.
- (4) Instruments repaired or disassembled by parties not authorized by TECLOCK can not be warranted by us.

Nomenclature

